

VENTILATED CABINET™

- Animal welfare
- Contamination Level
- Flexibility of configuration - Positive or Negative Pressure
- Large variety of configurations and complimentary equipment



"Thanks to the Tecniplast Ventilated Cabinets we can meet the higher standards required for the protection of both personnel and animals".



LAMINAR FLOW



TECNIPLAST
innovation through passion™

1/Introduction

Tecniplast Ventilated Cabinets are built in compliance with current legislation and are designed to safeguard animals and the environment in rodent holding rooms.

- Protection of immunodepressed, SPF animals.
- Protection of staff/local environment.
- To house animals of different strains or types within the same area.
- Suitable for specific studies or tests.
- To satisfactorily house animals in areas not specifically designed for their upkeep.

The ventilation system creates a clean environment for housing rodents in cages and minimizes the contamination level in the room air, thanks to the filtration system which continuously re-circulates the air through the filtration and reduces micro-organisms, dust and allergens and also reduces the risk of infections for animals.

2/Flexibility of configuration: Positive or Negative Pressure

The ventilated Cabinet is designed to work either in positive or in negative pressure mode.

When selected in positive pressure mode, the system is intended to protect the animals housed inside the cabinet from airborne contaminants of external environment.

When selected in negative pressure mode the system is intended to isolate animals housed inside the cabinet protecting operators and the environment from aeroallergens .

A horizontal air flow passes along the cages inside the cabinet removing ammonia vapours, carbon dioxide and odours before being filtered and exhausted into the environment via the grid positioned on the upper side of the cabinet.

HEPA filtered H14 efficiency (optional) and charcoal filtered (optional).

3/Large variety of configurations and options

All models have four separate compartments within which are two lateral plenums for incoming and exhaust air. Thus ensuring a complete gaseous exchange within the compartments, avoiding draughts and/or pockets of still air. Five compartments are available only with two apertures. The internal stainless steel solid shelves avoid spillage of diet etc into cages beneath and the maximum load capacity of each shelf is 20 kg uniformly distributed.

Different numbers of apertures are available: 2; 4 or 8.

The multi-door version allows to restrict the opened area at any one time, therefore providing a higher level of protection.

PVC transparent doors (standard configuration) or Polycarbonate red doors (optional only with day/night variable cycle) are available. Why red? Because mice see red as black, so they feel to stay as a secure dark environment. Whereas staff can see through the transparent plastic, making daily checks easy without disturbing the animals.

Other available options are:

- The air heating system with thermostatic control and air flow alarm to set the air temperature inside the chamber.
- Variable day/night cycle timer to set the number of lighting hours inside the chamber.



LAMINAR FLOW

Ventilated Cabinet

Introduction

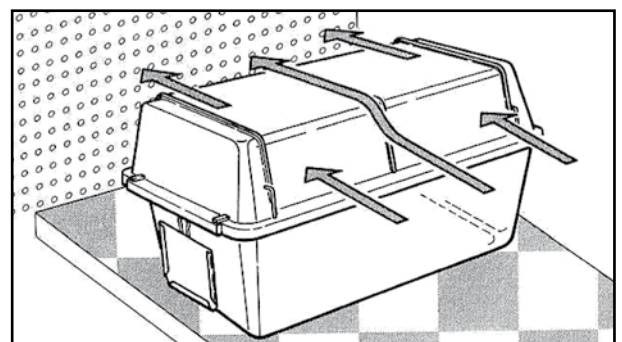

Flexibility of configuration **2**

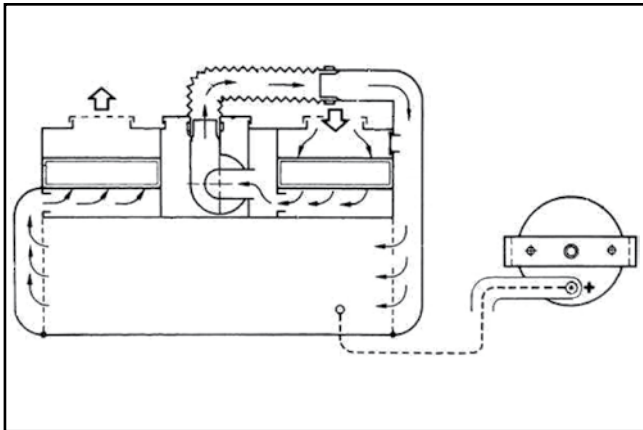
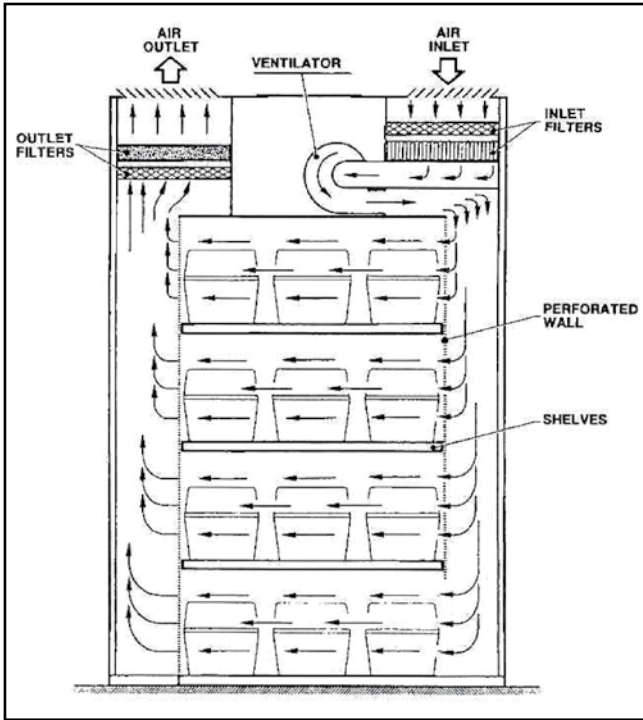

TECHNICAL SHEET

CABINET CODE	Cage Capacity					
	1144B	1264C	1284L	1290D	2150E	1291H 2154F
9AV(x)24	28	28	16	12	16	12
9AV(x)25	35	35	20	-	-	-
9AV(x)44	28	28	16	12	16	12
9AV(x)84	28	28	16	12	16	12

(x) = electrical configuration (it varies locally)

Overall dimensions (L x W x H)
1020 x 650 x 1900 mm • 40.16 x 25.6 x 74.8 inch

Electrical supply
Supply voltage: 230 V 50/60 Hz - 115 V 60 Hz
Installed power: 150 W
Fluorescent lights (optional): 50 W
Heating element (optional): 200 W

Fans - centrifugal type at low differential pressure and variable speed
Maximum throughput: 288 m³/h • 169.51 CFM
Maximum air change/hour (ACH): 70

Filters
Pre-filter dimensions: 305 x 305 x 23 mm • 12 x 12 x 0.9 inch
HEPA filter dimensions (optional): 305 x 305 x 68 mm • 12 x 12 x 2.7 inch
Charcoal filter (optional): 305 x 305 x 48 mm • 12 x 12 x 1.9 inch

Weight:
Net weight: 165 Kg

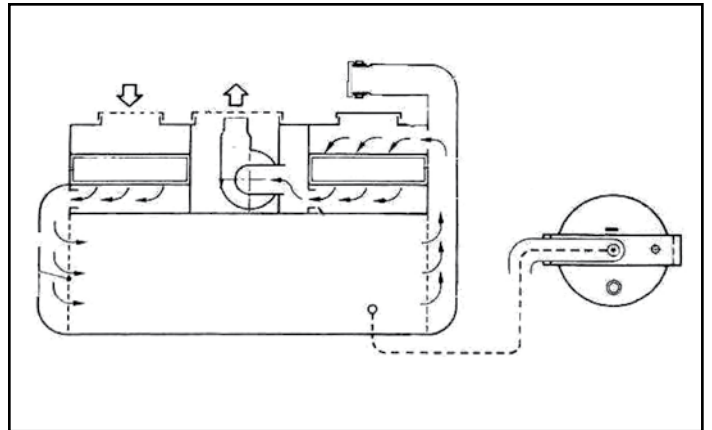

Large variety of configurations and options **3**

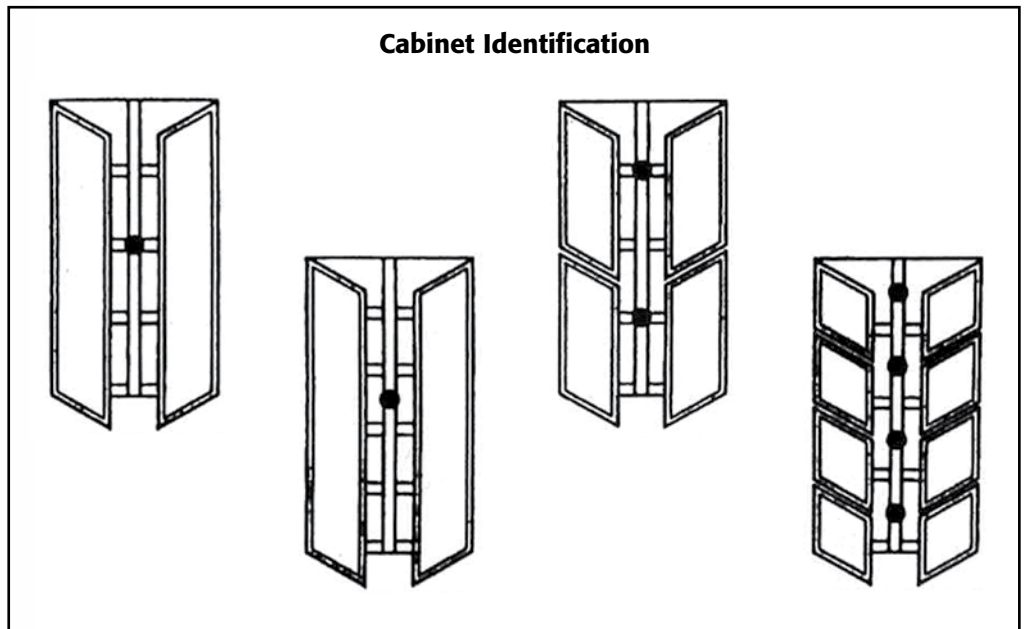

Main Features

- Stainless Steel main structure.
- Anti-reflective external finish
- Front doors with panels. The following kinds of panel are available:
 - Transparent panels.
 - Red transparent panels (available only with Variable day/night cycle timer option).
- Internal stainless steel shelves.
- Castors with brakes.
- Control panel with pressure reader.
- Optional heating elements and temperature reader.
- Fan speed adjuster.
- May be run in either positive or negative pressure mode, by changing configuration.
- Optional pre-settable lighting system timer inside the cabinet (Variable day/night cycle timer).

Related Products

To maximise operational efficiency and learn more about these products contact your local representative.



Conventional Cage.
Tecniplast offers a wide range of flexible, durable, autoclavable and ergonomic static cages.



650 Series Cabinet Washer.
High throughputs rates, short cycles and environmental friendly.



Logistic trolleys offer safety and ergonomic features that enable high load-density for moving cages and bottles, crates, pallets and covers.

TECNIPLAST

HEADQUARTERS

ITALY | Tel. +39 0332 809711 • www.tecniplast.it • E-mail: tecnicom@tecniplast.it

SISTER COMPANIES

AUSTRALIA/NEW ZEALAND | Tel. + 61 2 8845 6500 • www.tecniplast.it • E-mail: info@tecniplast.com.au

FRANCE | Tél. 04 72 52 94 41 • www.tecniplast.fr • E-mail: info@tecniplast.fr

GERMANY | Tel. 08805 921320 • www.tecniplast.de • E-mail: info@tecniplast.de

UNITED KINGDOM | Tel. 0845 0504556 • www.tecniplast.it • E-mail: info@tecniplastuk.com

JAPAN | Tel. + 03 5770 5375 • www.tecniplast.it • E-mail: info@tecniplastjapan.co.jp

USA/CANADA | Toll Free: 877.669.2243 • www.tecniplastusa.com • E-mail: info@tecniplastusa.com

To find your local distributor, please visit www.tecniplast.it



ISO-9001 - Cert. n° 0875



ISO-14001 - Cert. n° 0256A/D



Tecniplast reserves the right to change or modify product and or specifications without notice or obligation.
Ventilated Cabinet is a Tecniplast trademark.